

A - A

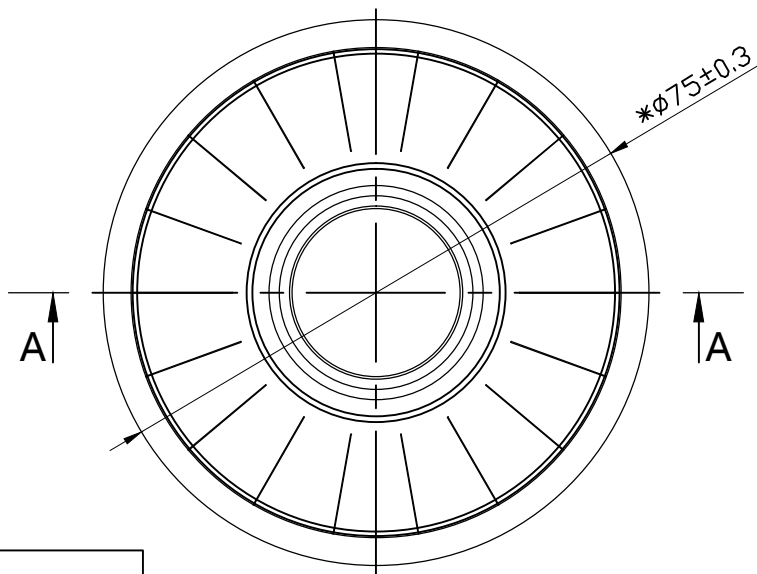

Light Source	TYF TX1-19175-1312BB
Plastic Holder	92.70.412.00
Metal Adaptor	
Design Angle	36°±3°
Measured Angle	37°
Efficiency	96.85%

光学装配示意图

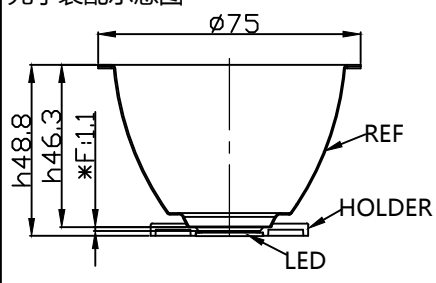

技术要求:

1. 材质: 详见BOM表。
2. 未注公差按尺寸公差表。
3. 产品未注圆角与拔模斜度按3D。
4. 产品外观按《N-SIP-QA-04 铝反光杯检验标准》。

产品BOM

序号	产品名称	产品编号	数量	材料/表面处理
①	2-2809-A	94.02.2809.000	1	T=0.4mm MIRO98AX4
②	2-2360-M焊接片	97.77.011.00	1	T=0.6mm 1060AL H22

标记 MARK	处数 NO. OF MODIF.	更改内容 MODIFICATIONS	签名 SIGNED BY	更改日期 MODIF. DATE
设计 DESIGNER		制图 DRAWN BY	比例 SCALE	1:1
工艺 TECHNICAN		审核 CHECKED BY	视角 1st ANGLE PROJECTION	
批准 APPROVED BY		日期 DATE (DD-MM-YYYY)	页数 PAGE	SHEET 1 OF 1

DIMENSION TOLERANCE TABLE (UNLESS OTHERWISE STATED)						
未注尺寸公差表						
> 0-5	> 5-30	> 30-90	> 90-150	150-250	250-400	400-700
±0.15	±0.2	±0.4	±0.5	±0.8	±1.5	±2
PUNCH TOLERANCE TABLE (UNLESS OTHERWISE STATED) (ANGLE)						
角度公差表 (单位: 度)						
> 0-10	> 10-50	> 50-120	120-250	250-360		
±1°	±0.5°	±0.3°	±0.2°	±0.166°		

**Nata**<sup>®</sup> 版本  
VERSIONS  
K0

产品编码 PRODUCT CODE	91.02.2808.000
产品名称 PRODUCT NAME	2-2808-L
客户代号 CUSTOMER ID	NT
客户编号 CUSTOMER CODE	AV-D75H-36D反光罩

**产品图**  
PRODUCT DRAWING

单位  
UNIT  
mm